

BPM-ZL1-3L GALAXY INSTRUKCJA OBSŁUGI/ MANUAL/ GEBRAUCHSANWEISUNG

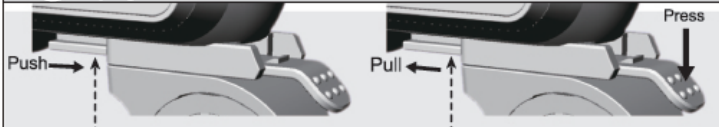

T Type fixer
Push forward the T Type Fixer into the Wedge of Bracket.

T Type fixer
Press downward the Plastic Strip and pull out the Bike Light.

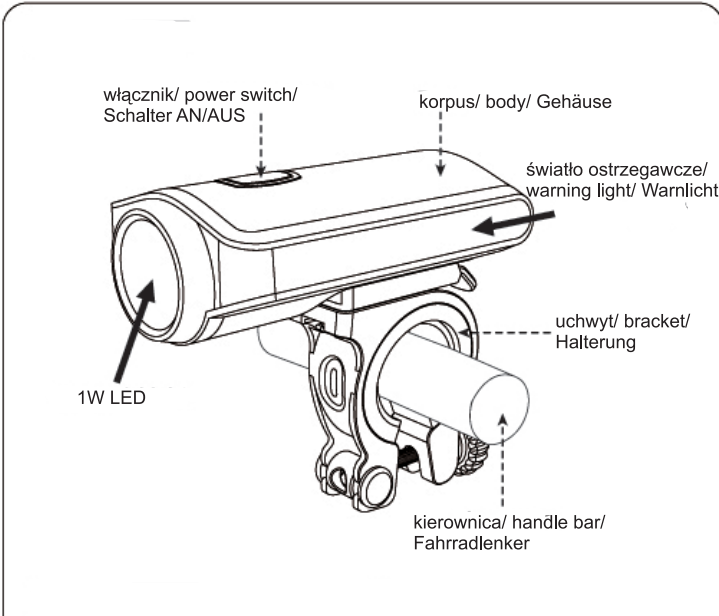
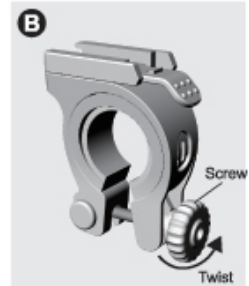
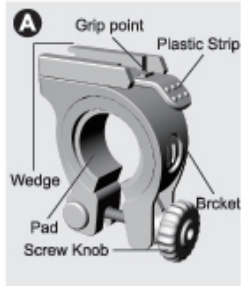
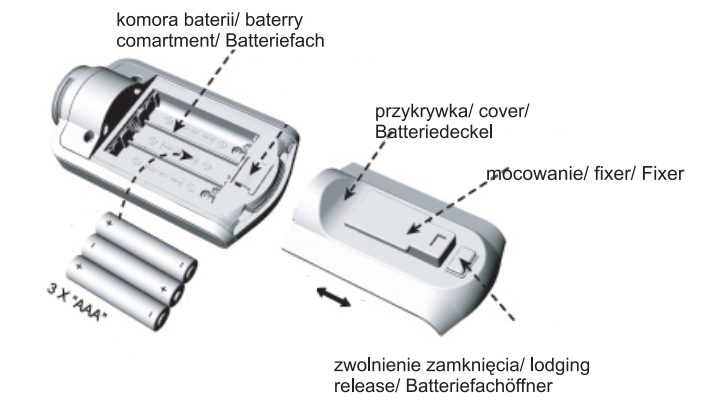

Przekręć pokrętko śruby odwrotnie do ruchu wskazówek zegara/ Twist the screw knob counterclockwise/ Drehschraube gegen den Uhrzeigersinn drehen

Obróć w dół pokrętko śruby/ press downward the screw knob off the bracket/ Drehschraube nach unten von der Halterung wegdrücken

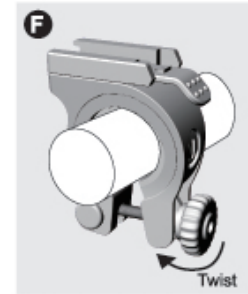
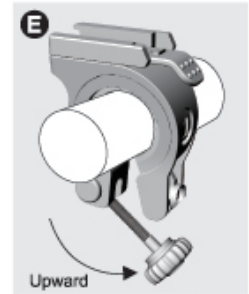
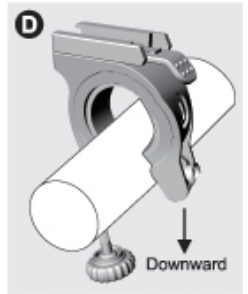

Przymocuj uchwyty do kierownicy nasuwając go/ Push downward the bracket to hook in the bar/ Halterung auf den Fahrradlenker aufsetzen und nach unten drücken

Umieść pokrętko śruby z powrotem w uchwyty/ Place the Screw Knob back to the Bracket/ Drehschraube nach oben in die Halterung schieben

Przekręć pokrętko śruby zgodnie z ruchem wskazówek zegara do maksymalnego zacieśnienia/ Twist the Screw Knob clockwise and tighten to complete installation/ Drehschraube im Uhrzeigersinn fest zudrehen

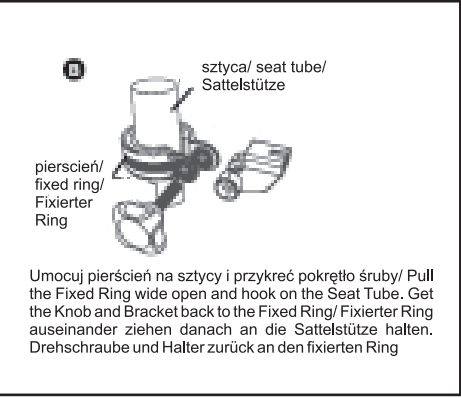

Umocuj pierścień na sztycy i przykręć pokrętko śruby/ Pull the Fixed Ring wide open and hook on the Seat Tube. Get the Knob and Bracket back to the Fixed Ring/ Fixierter Ring auseinander ziehen danach an die Sattelstütze halten. Drehschraube und Halter zurück an den fixierten Ring

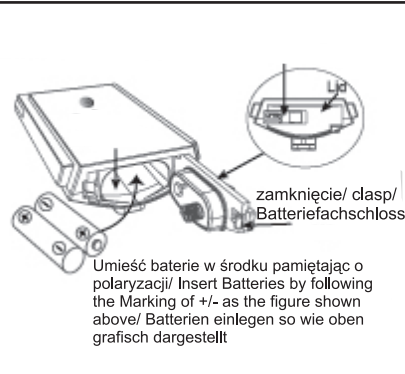
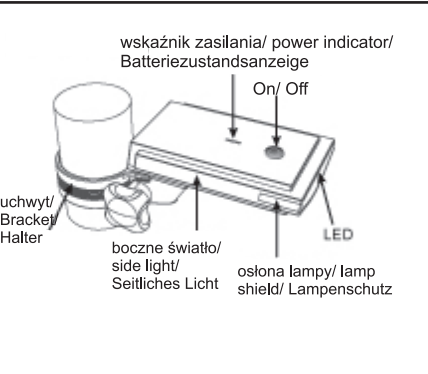
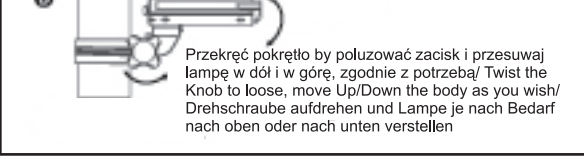
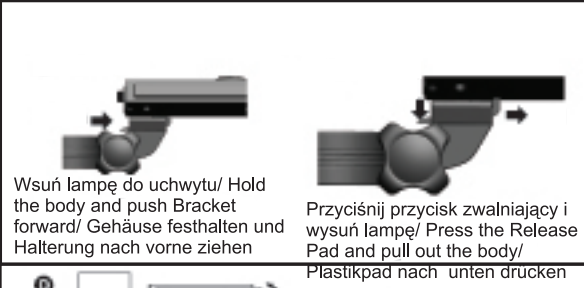

Umieść baterie w środku pamiętając o polaryzacji/ Insert Batteries by following the Marking of +/- as the figure shown above/ Batterien einlegen so wie oben grafisch dargestellt